

# Assembly Manual

## ESR Meter Mk.2

Cat No. **K 7214**

by *Bob Parker*

PROJECT INFORMATION SUPPLIED BY  
Main Electronic Supplies Ltd



WEBSITE: www.mainelectronics.com  
E-MAIL: info@mainelectronic.com

Please read Disclaimer carefully as we can only guarantee parts and not the labour content you provide.



A.B.N. 34 000 908 716



*Forget about capacitance meters - an ESR meter is the way to go when it comes to identifying faulty electrolytics. This well-proven design is autoranging, low in cost and simple to build.*

IT'S HARD TO BELIEVE that it's already eight years since my first ESR (equivalent series resistance) meter was described – in the January 1996 edition of "Electronics Australia". It was designed on a 386 PC!

The ESR meter allowed service technicians to quickly and easily identify defective electrolytic capacitors while they were still in circuit. It measures a characteristic of electrolytic capacitors which is very important: the "equivalent series resistance" or ESR.

Back then, no-one (including myself) expected that a meter designed to measure a capacitor characteristic hardly anyone had ever heard of would become popular in Australia, let alone overseas. However, we didn't consider the explosive growth of the Internet. Thanks to people discussing it on various news-groups and by email, about 12,000 ESR

meter kits have now been sold and sales (mainly outside Australia) continue to be strong.

Over those eight years, both Dick Smith Electronics (which sells the kit) and the author have received many suggestions from constructors on improving the ESR meter kit – particularly on making the construction easier. This upgraded version is the result and incorporates many of those ideas. As before, it will be available as a complete kit from DSE.

### What's ESR?

Before taking a look at what's changed in this "Mk2" version of the ESR meter, let's take a look at what an ESR meter does. First, we need to get into a bit of boring theory to understand how electrolytic capacitors (which I'll refer to simply as "electrolytics" from here on) are constructed and work. This is neces-

sary to understand why they cause so many electronic faults.

Fig.1 is a simplified cross-section drawing which shows the basics. As with many other kinds of capacitors, the plates of an electrolytic consist of two long aluminium foil strips wound into a cylinder. The big difference is that the

### ESR Meter: Main Features

- In-circuit testing, made possible by using <100mV test voltage which won't forward bias diodes or transistors.
- Auto-ranging to cover 0.01-99Ω.
- Non-polarized test leads due to no DC component in the test signal.
- Single pushbutton to easily control all functions.
- Test lead resistance zeroing.
- Automatic switch-off after three minutes when the meter is idle.
- Low battery voltage warning – "b" blinks on the display.
- 13mm LED displays for easy viewing from a distance.
- Chart of typical electrolytic capacitor ESR figures on the front panel.



dielectric isn't a strip of plastic or other insulating material separating these plates, but an extremely thin layer of aluminium oxide which is formed directly onto the anode foil itself during the manufacturing process.

As part of an electrolytic's electrochemical operation and to achieve the closest possible electrical contact with the cathode side of the oxide layer, a separating strip of porous material (generally paper) is sandwiched between the plates. This separator is soaked with a highly conductive liquid called the "electrolyte", which effectively connects the negative plate to the oxide layer and gives the capacitor its name. In very old electrolytics, the electrolyte was water-based but they now use water-free formulas.

Because electrolytics make use of a conductive liquid to complete the electrical circuit between the cathode plate and one side of the dielectric, the electrolyte's electrical resistance is critical. It is the major component of the capacitor's "equivalent series resistance" or "ESR". Other components of ESR are the inductance of the wound capacitor element, the resistances of the internal connections and the impedance of the capacitance itself.

In operation, electrolytic capacitors can function perfectly for decades. However, there are some conditions which will cause the electrolyte's resistance (ESR) to increase. This can eventually reach a point where it causes problems for the circuit.

Normally, a flexible rubber seal keeps the electrolyte contained inside the aluminium case of the capacitor. If the seal fails (as it regularly does in surface-mount electrolytics), the electrolyte will leak and/or dry out.

The two other big killers are: (1) high temperatures where the electrolytic is located; and (2) high levels of ripple current through the capacitor, which cause elevated temperatures inside it. These conditions cause chemical changes to the electrolyte, increasing its resistance.

This is why time after time, repair technicians find electrolytics failing in switchmode power supplies, the deflection stages of CRT TVs and monitors, and other power circuitry such as electronically-commutated motors where both of those conditions are common.

### Why high ESR causes trouble

The function of an electrolytic capacitor is to block DC while acting as a low impedance to any AC voltage across it.

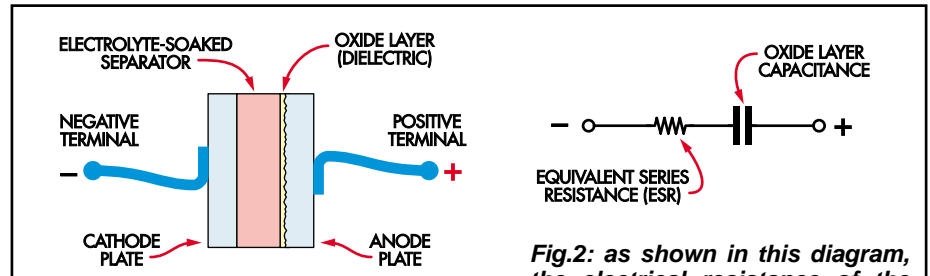

**Fig.1: simplified cross-section of an electrolytic capacitor. The dielectric consists of a thin layer of aluminium oxide on the anode plate and this is connected to the cathode plate via an electrolyte-soaked separator.**

**Fig.2: as shown in this diagram, the electrical resistance of the electrolyte is in series with the capacitance of the oxide dielectric. It is the major component of the "equivalent series resistance" or "ESR" of an electrolytic capacitor.**

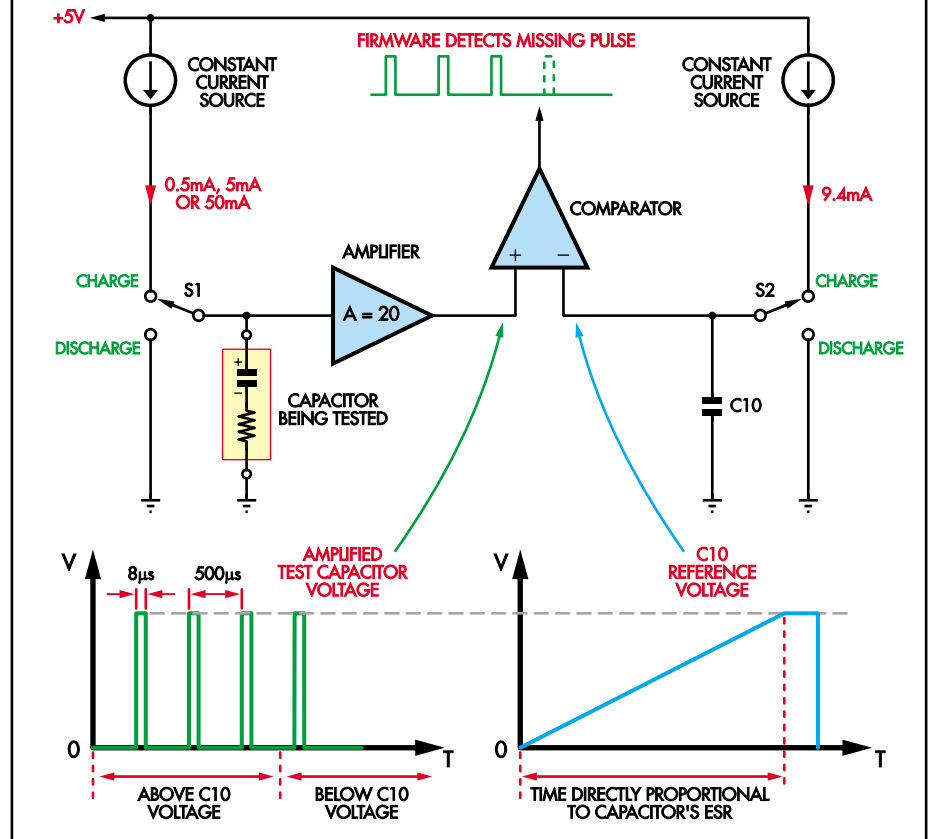

**Fig.3: this block diagram shows the basic scheme for the ESR meter. S1 is an electronic switch and it allows the test capacitor to be alternately charged for 8µs from a constant current source and then discharged for 492µs. The resulting voltage waveform is then amplified and fed to a comparator, where it is compared with a reference voltage ramp.**

As a power supply filter, an electrolytic smooths rectified voltage and so has to pass the AC ripple voltage on it. This causes "ripple" current through the capacitor.

In a perfect capacitor, such ripple current causes no internal heating or other problems but real world capacitors have ESR. The ripple voltage across this "equivalent series resistance" causes circuit losses as well as heating within the capacitor, if it becomes excessive.

For example, in switchmode power supplies, high ESR can cause starting failure, loss of regulation and excessive high-frequency noise on the outputs. Similarly, deflection circuits can suffer

from distorted and reduced scanning waveforms. In fact, high electrolytic capacitor ESR often causes strange problems which are hard to make sense of.

It's worth noting that ESR increases rapidly as the temperature drops. As a result, defective electrolytics are often indicated by faults which are worst in winter and when the equipment is first switched on, with the symptoms gradually diminishing as the temperature rises.

### Capacitance vs ESR meters

In the past, technicians didn't have much choice but to check suspect electrolytics using a capacitance meter. Unfortunately, capacitance meters are

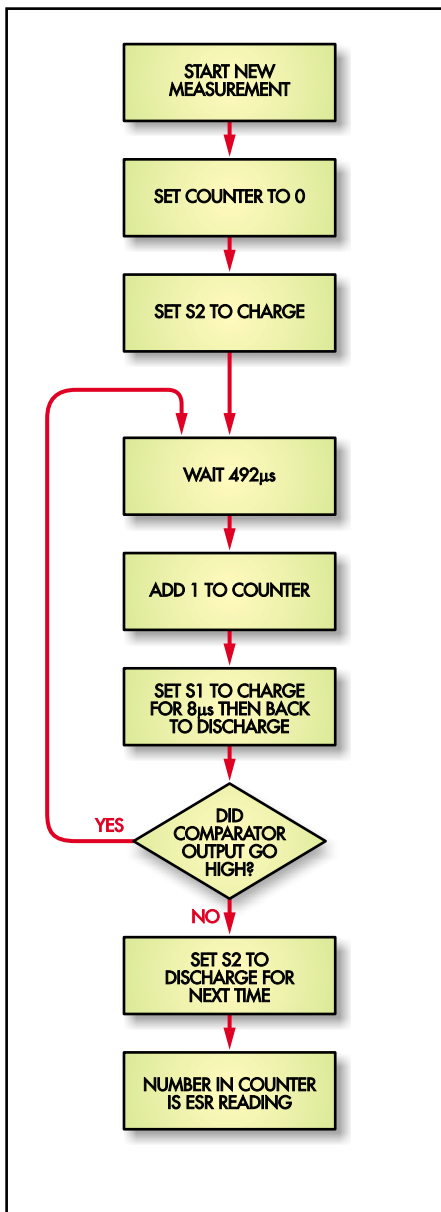

**Fig.4: this simplified flow chart shows how the microcontroller takes an ESR measurement. It simply counts the measurement pulses until the comparator output no longer goes high during one of them.**

generally useless for weeding out electrolytics which are causing trouble. They're generally designed to ignore the ESR and show only the actual capacitance which usually stays close to its correct value, even when the ESR has gone through the roof! In addition, the capacitor must be disconnected from the circuit before making capacitance measurements.

Now you can see why ESR meters have become so popular with technicians. They're designed to directly measure the very characteristic which is causing the fault.

What's more, this measurement can be made with the capacitor still in circuit (while the equipment is safely disconnected from power). This avoids the

inconvenience of having to unsolder it, which incidentally also heats it up and makes the ESR drop, thereby masking the problem.

### Microcontroller-based meter

Unlike most other ESR meters, this design is based on a microcontroller IC. This custom-programmed chip makes possible the extensive range of features offered (see panel). It also greatly contributes to the small size, low cost and simplicity of the ESR meter.

The microcontroller drives two 7-segment LED displays to give a direct read-out of ESR measurement.

### How it works

An ESR meter's job is to measure the resistance of an electrolytic capacitor's electrolyte while (as far as possible) ignoring the capacitive reactance. Fig.3 shows a simplified diagram of how this is done in the ESR meter described here.

As shown, switch "S1" (in reality, an electronic switch driven by the microcontroller) alternately connects and disconnects the capacitor being tested to a constant current source of either 0.5mA, 5mA or 50mA (depending on the range). In practice, the capacitor is alternately charged for 8ms (S1 in the "Charge" position) and discharged for 492µs (S1 in the "Discharge" position).

Because the test current pulses are so short, the voltage pulses developed across the capacitor are essentially proportional to its ESR. That's because capacitors with values above about 1µF don't have time to charge enough to significantly affect the reading.

The voltage pulses across the capacitor are fed to a non-inverting wideband amplifier with a gain of 20. The resulting signal is then applied to the non-inverting input of an op amp comparator (inside the microcontroller) and compared against a reference voltage which increases linearly with time.

### Analog-to-digital conversion

In operation, the test current pulses are applied to the capacitor at a constant rate of one every 500µs (ie, 8µs charge, 492µs discharge). At the same time, capacitor C10 is charged via another constant current source, so that its voltage increases linearly at a rate of 10mV/500µs. The resulting linearly increasing voltage on C10 is applied to the inverting input of the comparator.

As a result, the comparator's output will go high during each ESR measurement pulse, until C10's voltage exceeds

the pulse amplitude. When that happens, the comparator's output stays low and the missing output pulses are detected by the firmware in the microcontroller.

Fairly obviously, the number of pulses that occur up until this point is directly proportional to the capacitor's ESR. It's simply a matter of using the microcontroller to count these pulses to obtain a reading on the display (and microcontrollers are very good at counting).

Fig.4 shows the simplified flow chart of how the microcontroller takes an ESR measurement. It simply counts the number of measurement pulses until the comparator output no longer goes high during one of them.

### General operation

With the basics out of the way, let's now take a look at the complete circuit. Fig.5 shows the details. As can be seen, it's based on a Z86E0412 microcontroller.

Starting with the power supply, Q1 is the main power switching transistor. In the meter's "off" state, Q1 has no forward bias and so no significant current flows from the battery.

Conversely, when switch S1 is pushed, base current flows from Q1 and through resistor R2 and diode D1 to ground. Q1 thus switches on and effectively connects the battery's positive terminal to the input of 5V regulator IC1. This in turn provides a +5V rail to power microcontroller IC2 and the rest of the circuit.

As soon as power is applied, IC2's crystal oscillator (based on 3.58MHz crystal X1) starts and IC2 begins executing the instructions in its firmware. The first "external" thing it does is drive pin 2 to +5V and this turns on transistor Q2 via resistor R3 (15kΩ). As a result, Q2 takes over from pushbutton switch S1 in maintaining Q1's base current through R2, thus ensuring that the power remains on when S1 is released.

### Pulsed current sources

Transistors Q3, Q4 and Q5 are driven by pins 15-17 of IC2 (via 2.2kΩ resistors) and function as switches. Depending on the range chosen, the Z86 pulses one of these transistors on for 8µs every 500µs, to apply short current pulses via C5 & C6 to the capacitor being tested.

Resistors R6, R8 & R10 set the pulse current to either 0.5mA, 5.0mA or 50mA, while capacitors C5 and C6 block any DC component from reaching the test leads. Note that bipolar electrolytic capacitor C6 is in series with the current

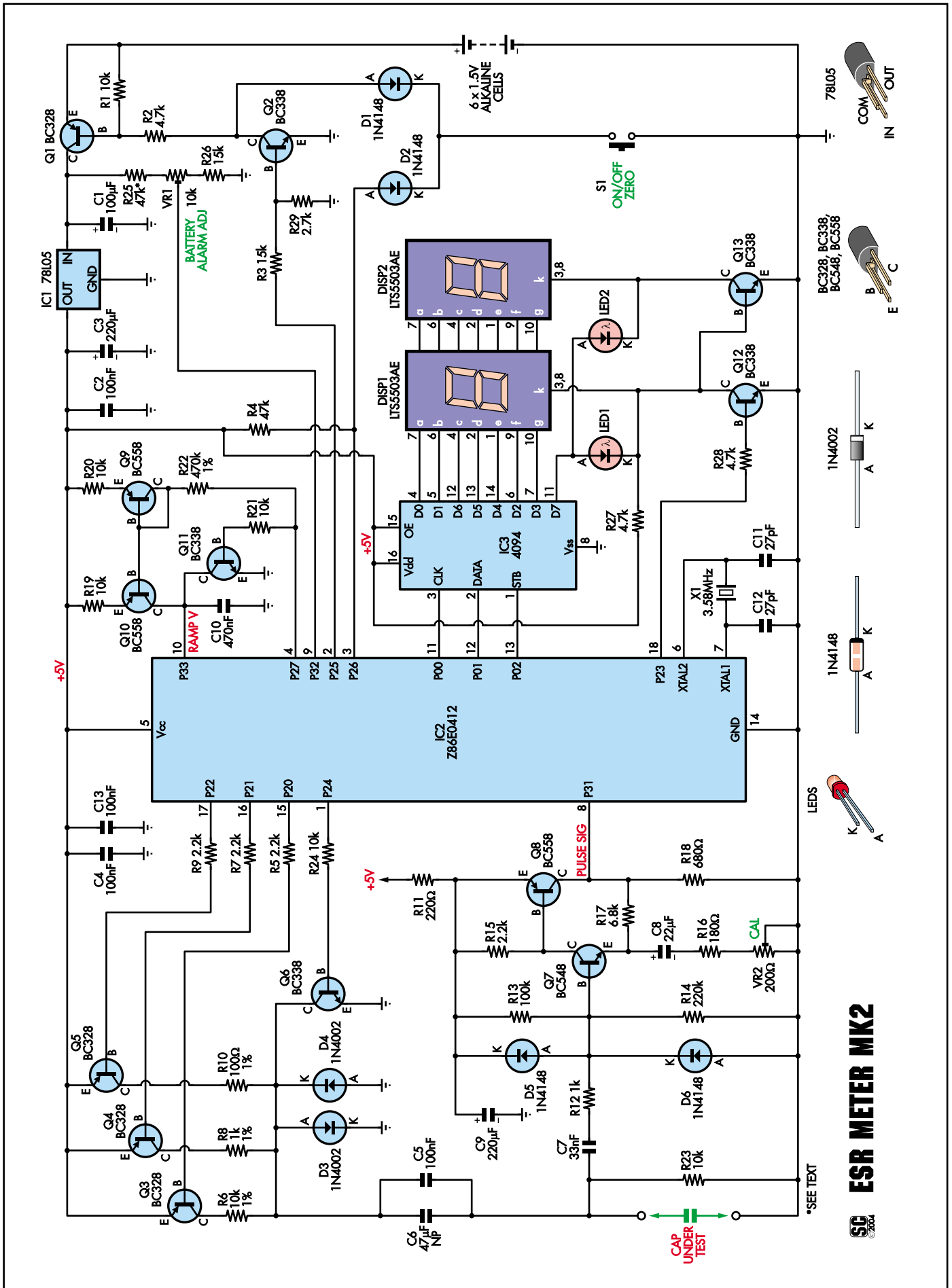
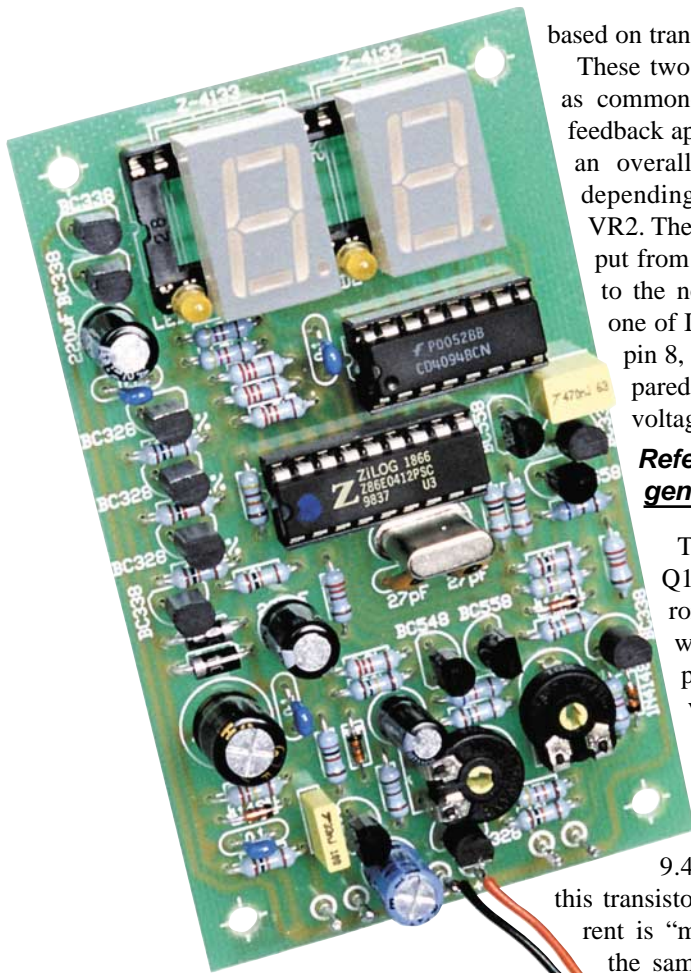

Fig.5: a Zilog Z86E0412 programmed microcontroller (IC2) forms the heart of the circuit. This IC automatically switches transistors Q3-Q5 to set the pulse current level, while Q7 & Q8 amplify the resultant voltage pulses across the test capacitor for comparison with a reference voltage ramp (across C10).



Here's a preview of the assembled PC board.

source resistors, so its own ESR is effectively "swamped" by the relatively high resistor values. C5 is included to preserve the high-frequency response of the pulse waveform and to further reduce the effect of C6's ESR.

Between the 8µs pulses, IC2 drives its pin 1 port to +5V. This turns Q6 on and discharges the series combination of C5/C6 and the capacitor under test.

### Pulse amplifier

The current pulses developed across the test capacitor are fed via C7 and R12 to a fast non-inverting pulse amplifier

based on transistors Q7 and Q8.

These two transistors are wired as common-emitter stages, with feedback applied via R17 to give an overall gain of about 20, depending on the setting of VR2. The amplified signal output from this stage is then fed to the non-inverting input of one of IC2's comparators via pin 8, so that it can be compared with the reference voltage.

### Reference voltage generator

Transistors Q9 and Q10 form a current mirror circuit which works with capacitor C10 to provide the reference voltage (see Fig.3). It works like this: when Q9 is on (ie, when pin 4 of IC2 is low), approximately 9.4µA flows through this transistor and R22. This current is "mirrored" by Q10, so the same amount of current also charges C10 (470nF) at a linear rate towards the +5V supply for as long as pin 4 of IC2 is held low.

The ramp voltage developed across C10 is applied to pin 10 of IC2. This pin is the common inverting input of the two voltage comparators inside the Z86. Q11 discharges C10 when IC2 switches its pin 4 port to +5V at the end of each measurement cycle.

### Range changing

While ever the power is switched on, the Z86 goes through a regular measurement routine in which it starts C10's voltage ramping up and then drives either Q3, Q4 or Q5 with 8ms pulses that are 500ms apart. This produces measure-

ment ranges of 0.00-0.99Ω, 1.0-9.9Ω and 10-99Ω.

If a reading is offscale, the unit automatically drops to the next lowest test pulse current and checks again. However, if it's already on the 10-99Ω range and the reading is offscale, it will display "-" to indicate a reading above 99Ω.

Conversely, if it gets a very low reading, it will keep going to the next highest test current, until it's found the highest on-scale reading. The reading is then shown on the 7-segment LED displays.

### Driving the displays

To display the reading, the Z86 microcontroller sends out eight bits of data (in sequence) every 5ms to IC3, a 4094 serial-to-parallel shift register. These data bits correspond to the LED display segments and to the decimal points which are formed using LEDs 1 & 2.

In operation, the LED displays (DISP1, DISP2 and LEDs 1 & 2) are switched at a 100Hz rate by transistors Q12 and Q13. Q12 is driven (via R28) from the P23 output (pin 18) of IC2, while Q13 is biased on via R27, which connects directly to the +5V rail. Q13 toggles off when Q12 turns on and turns back on again when Q12 turns off.

Due to the slow response of the human eye, the displays all appear to be constantly illuminated. This technique is called "multiplexing" and it allows the two displays to share a common drive circuit.

### Test lead resistance zeroing

The resistance of the test leads can be compensated for by again pressing switch S1 (ie, after the unit has been powered up) while the test lead probes are held tightly together (to minimise contact resistance). When this is done, pin 3 of IC2 is pulled low via D2 and S1 and the microcontroller goes into its test lead zeroing routine.

If the reading is less than 1Ω (as all test leads are), it saves this value for as long as the meter is switched on. It then subtracts it from all subsequent readings, so that only the ESR of the capacitor being tested is displayed (ie, so that the reading is unaffected by the test lead resistance).

### Switching off

Pressing S1 while the test leads are separated (or connected to a resistance of 1Ω or higher) initiates the "switch-off" routine (assuming, of course, that the unit is already on).

What happens is that the Z86 stops

## What's Changed In The Mk.2 Version

- Front panel chart figures updated to reflect current-generation electrolytic capacitors.
- PC board now has silk-screened component overlay, solder masking and holes under the trim pots for adjustment after final assembly.
- Improved appearance, with countersunk screws, etc.
- Automatic switch-off time increased from two minutes to three minutes.
- Holder for 6 AAA cells instead of a 9V alkaline battery for longer times between battery replacements (and to finally end constructor confusion about how to keep the battery in place).
- Smaller more reliable pushbutton switch which is harder to accidentally bump in a toolbox.
- Automatic self-testing of the meter's circuitry added to the microcontroller firmware, to simplify fault-finding if a newly-built meter doesn't work properly.

making measurements and switches its pin 2 port to 0V, in turn switching off transistor Q2. Then, when you release S1, Q1 switches off and the meter shuts down.

In addition, the ESR Meter includes an automatic power-off function. This shuts the meter down if it has been idle for more than three minutes.

It works like this: as long as the meter is actively taking readings, it keeps resetting a 3-minute timer function in the Z86 microcontroller. However, if the unit is left idle (even with the test leads touching), the Z86 automatically switches its pin 2 port low after three minutes, thus turning off the power.

This automatic switch-off function may be a nuisance in some situations, however. Hence, it can be easily disabled if necessary (see the “Optional Modifications” panel on page 12.

### **Battery voltage warning**

A simple voltage divider consisting of trimpot VR1 and series resistors R25 & R26 makes up the battery warning circuit. This divider is connected across the switched battery voltage and VR1 is adjusted so that it applies 2V to pin 9 of IC2 when the battery voltage is at 7V (ie, the minimum at which the regulator will continue to regulate).

Pin 9 of IC2 is the non-inverting input of IC2's second internal comparator. In operation, IC2 switches its pin 4 port to 0V for a period of 100ms several times per second, to allow C10 to charge up to a predictable 2V. The second comparator inside IC2 then compares this 2V reference against the voltage on VR1's wiper.

If the battery voltage is down to 7V, IC2 reduces the time each LED display is switched on by 50%. This reduces the load, which allows the battery voltage to slightly rise again and provide a bit more operating time. It also flashes a “b” on the righthand digit at a 1Hz rate until the power is turned off.

### **Protection circuitry**

Last but not least, the meter needs to be protected against being connected to charged capacitors. This protection is partially provided by back-to-back diodes D3 and D4. If an external DC voltage (ie, a charged capacitor) is connected, one of these diodes conducts and forces non-polarised capacitors C5 and C6 to charge up to that voltage.

Additional protection is provided by C7, R12, D5 & D6 which stop excessive input voltages from damaging transistors Q7 and Q8 in the pulse amplifier circuit.

## **What Are Typical ESR Readings?**

So what are typical ESR readings for various electrolytic capacitors? Unlike other electrical characteristics, there's no such thing as a “normal” ESR value for an electrolytic of a given capacitance and operating voltage. The ESR to a large extent depends on the physical size of the capacitor and whether it's a low-ESR or high temperature-rated type. It also varies between manufacturers. In addition, ESR increases rapidly as the temperature drops and vice versa.

The chart on the front of the meter contains sample ESR values for a range of common electrolytic capacitor values and voltage ratings. These have been derived both from physical measurements on a range of capacitors and from manufacturer's data sheets. It's only intended as a rough guide, to give an idea of what to expect until you become familiar with using the ESR meter.

In particular, diodes D5 & D6 acts as voltage clamps – D5 ensures that the voltage on Q7's base cannot go above 5.6V, while D6 ensures that this voltage cannot go below -0.6V.

Finally, extra “heavy-duty” protection can be added by connecting a pair of back-to-back high-power diodes (not shown on the circuit) between the test terminals. The “Optional Modifications” panel on page 12.

### **Construction**

Even if the ESR Meter's operation seems complicated, at least it's easy to build. As you can see in the photos, all the components except for the battery holder, test sockets and the pushbutton switch are mounted on a single PC board. This in turn is attached to the front panel using spacers and machine screws.

The very first thing to do is glue the display window to the inside of the front panel, using a few drops of an adhesive such as contact cement around its edges. This can then be put aside to dry while you assemble the PC board.

Although a high-quality, solder-masked PC board is supplied, it's still wise to check it for defects. To do this, illuminate the component side with a bright light and examine the copper side very carefully – preferably with a magnifier – for any hairline fractures in the tracks. Check also for any solder “whiskers” or bridges and pay particular attention to any tracks which pass between IC socket pads, where such defects tend to congregate and hide.

Because of the need to make it fit into a compact plastic case, the PC board is tightly packed and the solder pads are quite small. The last thing this circuit needs is solder bridges and bad joints, so be very careful with your soldering. Always lift the iron vertically from a just-soldered joint and never wipe it sideways as so many constructors seem to do!

Construction is easiest if you begin by

installing the resistors and diodes first. Note that the kit for the Mk.2 version contains 1% resistors. It's notoriously difficult to correctly identify the colour bands on these, so check each one's value with an ohmmeter before soldering it to the board. Table 1 will help you select the resistor values prior to checking.

The larger components can now all be installed. These parts include crystal XTAL1, the electrolytic capacitors, trim-pots VR1 & VR2, the transistors, and the sockets for the LED displays and IC2 & IC3.

Note particularly that the 7-segment LED displays and LEDs are mounted on a 28-pin IC socket. Make sure that this socket is flat on the PC board before soldering its pins, otherwise the displays will foul the Perspex window when you later attempt to fit the front panel.

As usual, take care with the orientation of the polarised components; ie, the electrolytic capacitors, diodes and transistors. You should also make sure that the different transistor types all go in their correct places. Don't install the socketed parts just yet, though.

Once everything's on the PC board, hold the component side up to a bright light and carefully check for any solder bridges or other problems. In particular, check for light shining through the holes of unsoldered joints (this has been another common cause of problems with this kit).

### **LED displays**

Now for the LEDs and the 7-segment LED displays. First, cut the leads of the two decimal point LEDs down to about 8mm-long, then gently push them into their places in the 28-pin socket. Make sure that they are correctly oriented; ie, the flat side of each LED must go to the right – see Fig.6.

Next, insert the two 7-segment displays, ensuring that their decimal points are at the bottom and that they are prop-

## Parts List

- 1 PC board, code ZA1044, 95 x 57mm
- 1 3.58MHz crystal
- 1 16-pin IC socket
- 1 18-pin IC socket
- 1 28-pin IC socket
- 1 4 x AAA cell holder
- 1 2 x AAA cell holder
- 1 plastic utility box
- 1 miniature momentary-contact push button switch
- 2 4mm banana sockets
- 1 pre-punched silk-screened front panel
- 1 red perspex display filter
- 4 15mm spacers
- 6 PC pins
- 1 10k $\Omega$  PC-mount trimpot (VR1)
- 1 200 $\Omega$  PC-mount trimpot (VR2)

### Semiconductors

- 4 1N4148 or 1N914 signal diodes (D1,D2,D5,D6)
- 2 1N4004 power diodes (D3,D4)
- 4 BC328 PNP transistors (Q1, Q3,Q4,Q5)
- 5 BC338 NPN transistors (Q2, Q6,Q11,Q12,Q13)
- 1 BC548 NPN transistor (Q7)
- 3 BC558 PNP transistors (Q8, Q9,Q10)
- 1 78L05 3-terminal regulator (IC1)
- 1 Z86E0408 or Z86E0412 programmed microcontroller (IC2)
- 1 4094 / MC14094 CMOS shift register (IC3)

- 2 LSD5114 or LTS5503AE 7-segment LED displays (DISP1, DISP2)
- 2 3mm orange LEDs (LED1,LED2)

### Capacitors

- 2 220 $\mu$ F 16V RB electrolytic (C3,C9)
- 1 100 $\mu$ F 16V RB electrolytic (C1)
- 1 47 $\mu$ F 50V bipolar RB electrolytic (C6)
- 1 22 $\mu$ F 16/25V RB electrolytic (C8)
- 1 470nF 63V MKT (C10)
- 4 100nF 50V disc or monolithic (C2,C4,C5,C13)
- 1 33nF 63V MKT (C7)
- 2 27pF 50V NPO disc ceramic (C11,C12)

### Resistors (0.25W, 1% unless specified)

- |                 |                                     |
|-----------------|-------------------------------------|
| 1 470k $\Omega$ | 4 2.2k $\Omega$                     |
| 1 220k $\Omega$ | 2 1k $\Omega$                       |
| 1 100k $\Omega$ | 1 680 $\Omega$ $\sigma$             |
| 2 47k $\Omega$  | 1 220 $\Omega$                      |
| 2 15k $\Omega$  | 1 180 $\Omega$                      |
| 7 10k $\Omega$  | 1 100 $\Omega$                      |
| 1 6.8k $\Omega$ | 1 68 $\Omega$ (for calibration)     |
| 3 4.7k $\Omega$ | 1 5.6 $\Omega$ 5% (for calibration) |
| 1 2.7k $\Omega$ |                                     |

### Miscellaneous

Hookup wire, tinned copper wire, solder, flat washers, black counter-sunk selftap screws (No.4 x 6mm), black counter-sunk pan head screws (M3 x 6mm), double sided tape, heat-shrink tubing, test leads & instructions.

but don't connect them to the switch or test sockets for the time being.

### Initial checks

With IC2 and IC3 still out of their sockets, connect the supply leads to the batteries (or a 9V DC power supply), with a milliammeter in series with one of the supply leads.

Initially, you shouldn't see any current being drawn. Now short the pushbutton switch wires (the righthand ones when looking at the front) and check that the current drawn is now about 6mA. If it's significantly higher or lower, start looking for assembly errors (component placement errors, missed solder joints and solder splashes).

Assuming the current checks OK, connect the negative lead of a voltmeter to the negative battery lead, then check that there's +5V on pin 5 of IC2's socket and on pin 16 of IC3's socket.

If everything's OK to here, disconnect the 9V supply and the milliammeter. That done, discharge any static electricity you may have accumulated by touching something earthed, then install IC2 (Z86E0412PSC) and IC3 (4094) in their sockets. Double-check to ensure that these are both oriented correctly – their indented pin 1 ends are to the left.

Next, set both VR1 and VR2 to their mid-range positions, then separate the pushbutton switch leads and reconnect the 9V supply. Now short the pushbutton leads again and keep them shorted.

At this point, you should see something on the 7-segment LED displays, preferably "-" on the lefthand one. After five seconds, the displays should blank for a moment as the microcontroller does a basic check of the circuitry. If the next thing you see is ".8.8" for two seconds, it means that the board has passed the tests and is probably OK.

However, if you see an "F" on the lefthand display and a digit or "A" on the righthand one, the microcontroller has

erly seated. It might be necessary to snip a bit off their leads to get them to sit flat on the socket.

### External wiring

When all the components are on the board, solder two 150mm lengths of hookup wire to the battery pads on the PC board - red to "+" and black to "-".

The pushbutton switch terminals and test lead sockets are quite close to the PC board once everything has been mounted on the front panel. As a result, you can connect them to the PC board using the tin copper wire supplied. Alternatively, you can use short lengths of the supplied hookup wire.

Solder these leads to the PC board now

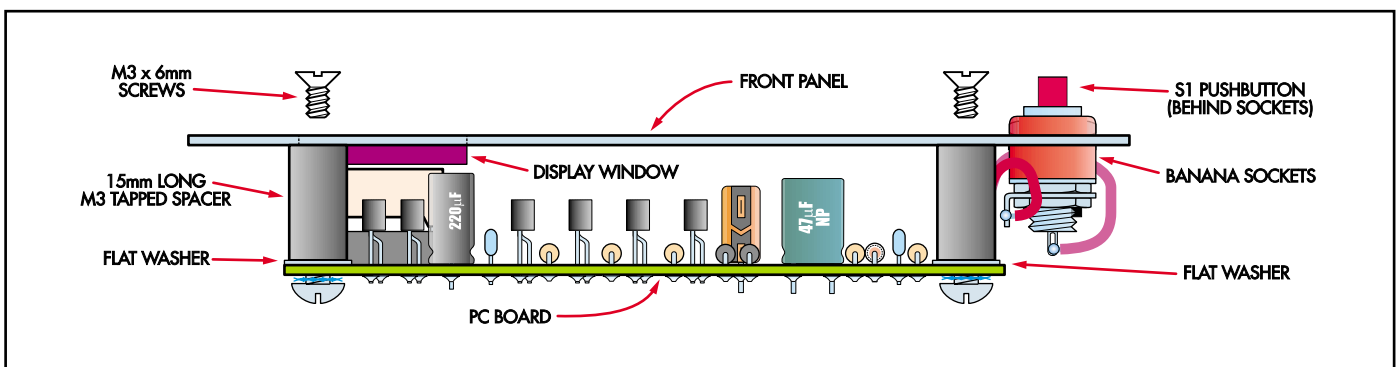
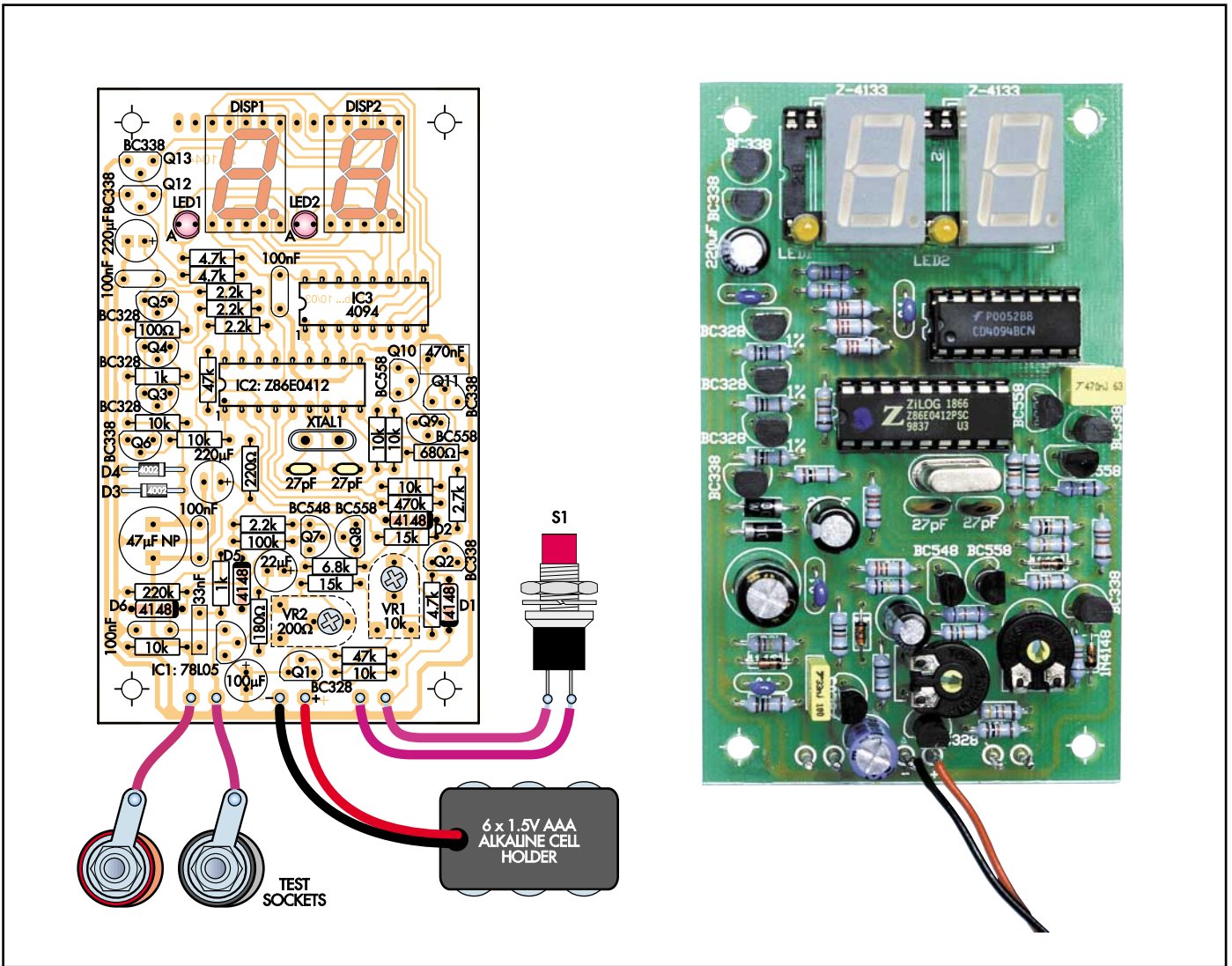

Fig.7: the PC board is attached to the underside of the front panel using 15mm-long tapped spacers, flat washers and M3 x 6mm machine screws.



**Fig.6:** Install the parts on the PC board as shown here but don't install IC2 or IC3 until after the initial checks described in the text have been made.

detected a problem. In that case, go to the "Fault Codes" panel to find out what to check for.

At this point, you can mount the test lead sockets onto the front panel – see Fig.7. Note that plastic insulating rings

are supplied with these sockets. As shown in Fig.7, these must be installed between the lugs and the front panel, not under the tops of the sockets. Many constructors of the Mk.1 version overlooked this and placed the lugs directly on the

metal panel, thereby short-circuiting them! Also refer to Fig.11 for correct socket mounting.

Next, mount the pushbutton switch, using small pliers to gently tighten the nut and being careful not to slip and scratch the panel. That done, fasten the standoffs to the board using 3mm screws, then mount the whole assembly on the front panel using the black countersunk 3mm screws supplied. If the LED displays foul the Perspex window, use the supplied washers to further space the board from the front panel.

Finally, complete the assembly by connecting the wires to the pushbutton switch and test lead sockets, and by soldering the supply leads to the battery holder. See Fig.10a & 10b.

### Calibration

Now for the calibration. The step-by-step procedure is as follows:

(1) Plug in the test leads, then push the button. You should see "-" on the left-hand display, indicating that the meter is seeing an ESR/resistance that's greater

**Table 1: Resistor Colour Codes**

Value	4-Band Code (1%)	5-Band Code (1%)
470kΩ	yellow violet yellow brown	yellow violet black orange brown
220kΩ	red red yellow brown	red red black orange brown
100kΩ	brown black yellow brown	brown black black orange brown
47kΩ	yellow violet orange brown	yellow violet black red brown
15kΩ	brown green orange brown	brown green black red brown
10kΩ	brown black orange brown	brown black black red brown
6.8kΩ	blue grey red brown	blue grey black brown brown
4.7kΩ	yellow violet red brown	yellow violet black brown brown
2.7kΩ	red violet red brown	red violet black brown brown
2.2kΩ	red red red brown	red red black brown brown
1kΩ	brown black red brown	brown black black brown brown
680Ω	blue grey brown brown	blue grey black black brown
220Ω	red red brown brown	red red black black brown
180Ω	brown grey brown brown	brown grey black black brown
100Ω	brown black brown brown	brown black black black brown
68Ω	blue grey black brown	blue grey black gold brown
5.6Ω	green blue gold brown	green blue black silver brown

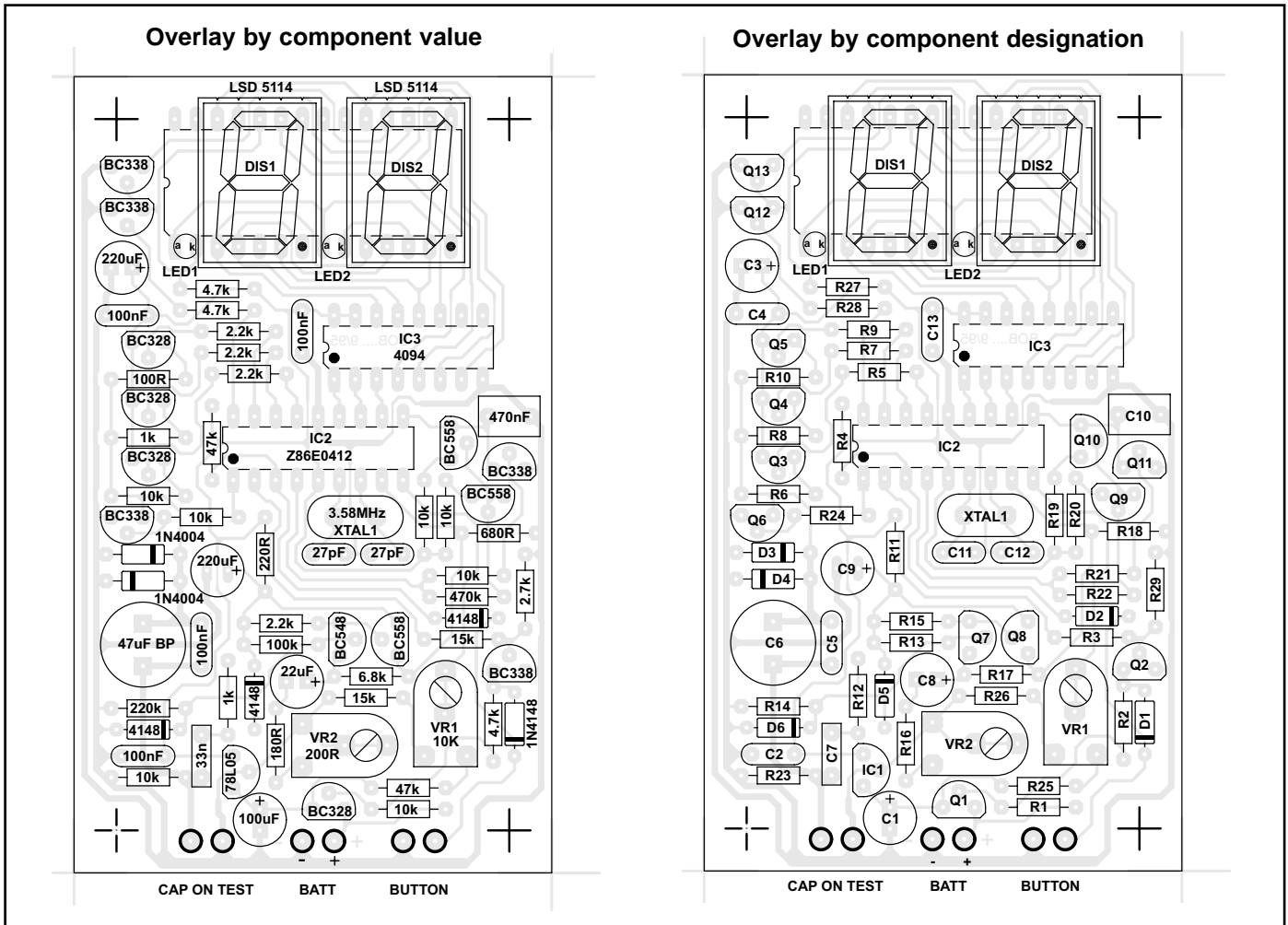

Fig.9a & 9b: Shows the PCB overlay with both component values and component designations. This can be very helpful in a service or fault-finding situation when the constructor needs to cross-reference between the two.

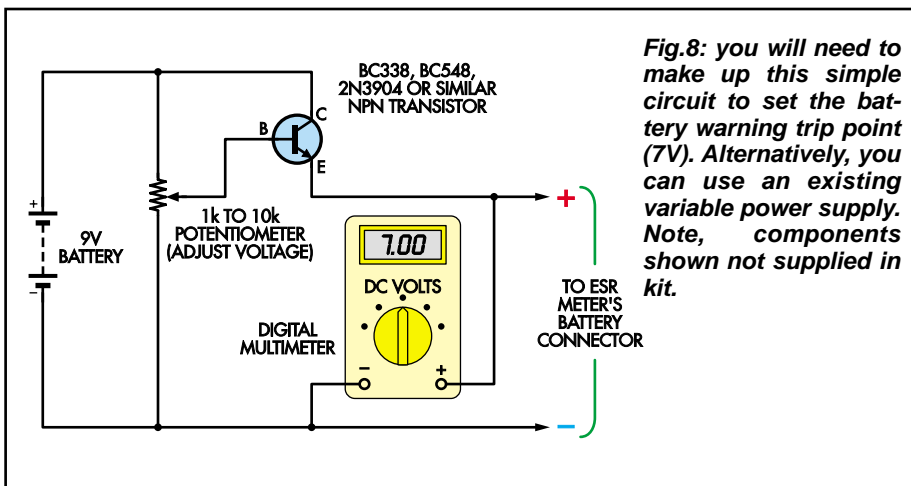

Fig.8: you will need to make up this simple circuit to set the battery warning trip point (7V). Alternatively, you can use an existing variable power supply. Note, components shown not supplied in kit.

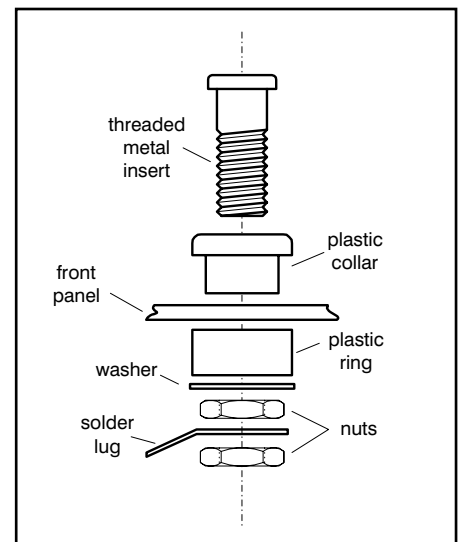

Fig.11: The front panel is mounted between the plastic collar and ring of the banana socket. Then two nuts are used to hold and lock the assembly in place.

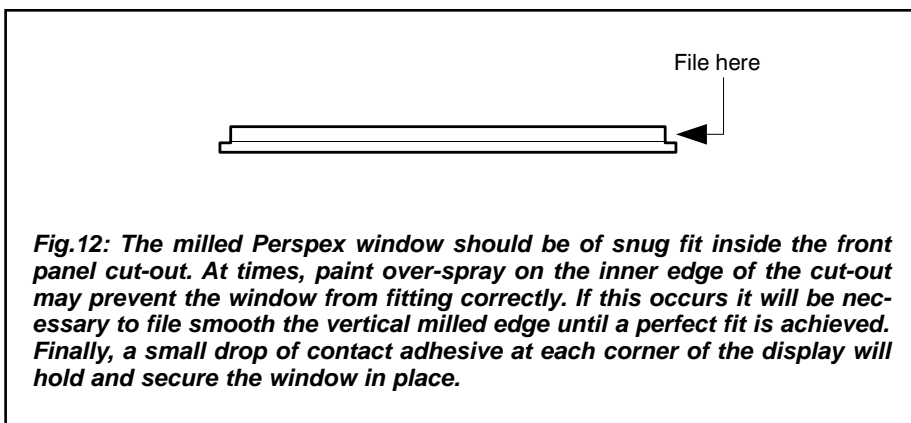
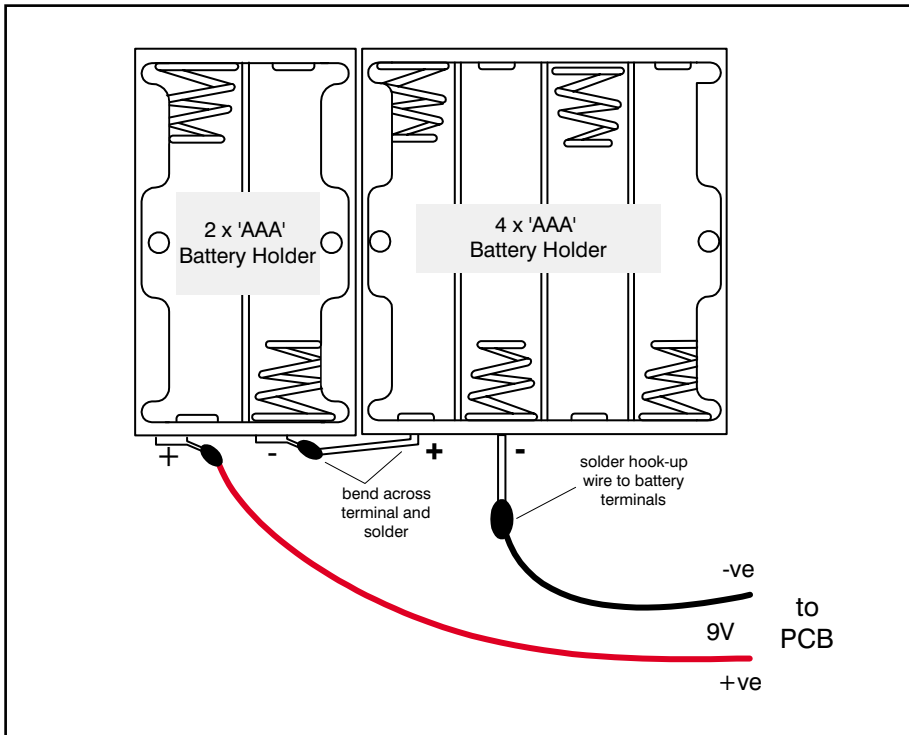
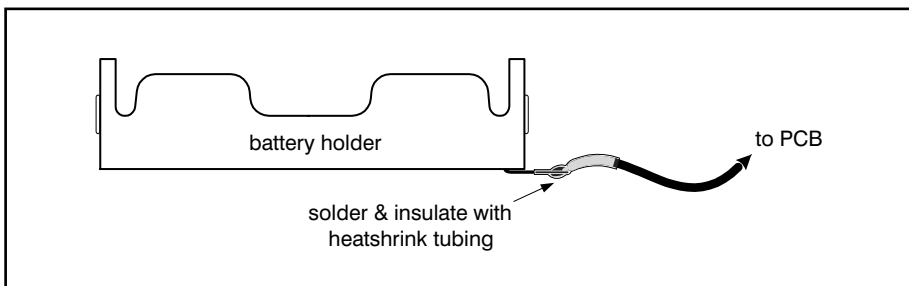

Fig.12: The milled Perspex window should be of snug fit inside the front panel cut-out. At times, paint over-spray on the inner edge of the cut-out may prevent the window from fitting correctly. If this occurs it will be necessary to file smooth the vertical milled edge until a perfect fit is achieved. Finally, a small drop of contact adhesive at each corner of the display will hold and secure the window in place.

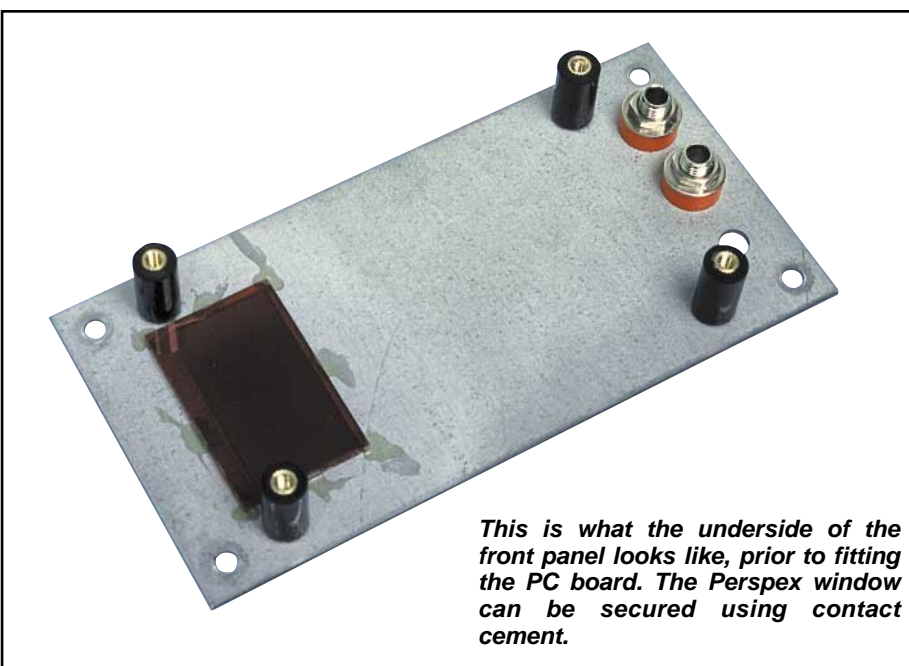



**Fig.10a: Two battery holders connected in series are used for the battery source. Connect and solder the inner terminals as shown, then solder a short length of hook-up wire to each of the outer terminals completing the positive (+ve) and negative (-ve) supply leads.**



**Fig.10b: Bend the battery terminals on the 4 x 'AAA' holder at 90 degrees and solder a short length of black hook-up wire to the negative (-ve) terminal. A piece of heatshrink tubing can be used to insulate the solder joint. Now bend the positive (+ve) terminal across and solder to the adjacent (-ve) terminal of the 2 x 'AAA' battery holder. Further details are shown above in Fig.10a.**



**This is what the underside of the front panel looks like, prior to fitting the PC board. The Perspex window can be secured using contact cement.**

than its maximum reading of 99Ω.

(2) Short the test leads together. The meter will display their resistance, typically 0.2-0.5Ω. Pushing the button again with the leads shorted should change the display to “.00” as the meter zeros out their resistance. However, it’s normal for this reading to change a bit, due to variations in contact resistance between the probes (remember that we’re measuring hundredths of one ohm!).

(3) Connect the supplied 68Ω 1% calibration resistor to the probes and carefully adjust VR2 until the meter reads “68”. That done, check that it reads the supplied 5.6Ω calibration resistor reasonably accurately.

### **Battery warning setup**

Skip this bit if you disabled the automatic switch-off function by leaving one lead of R25 disconnected (see the “Optional Modifications” section).

This adjustment is easiest if you have access to a variable DC power supply. If not, you’ll need to temporarily build the little circuit shown in Fig.8. The adjustment procedure is as follows:

(1) With the meter off, unplug the test leads and turn VR1 fully anti-clockwise (as viewed from the copper side of the PC board).

(2) Adjust the supply voltage to 7.0V, then switch the meter on.

(3) Slowly turn VR1 clockwise until the “b” battery warning indication begins flashing on the righthand display.

(4) Turn the meter off, wind the power supply back up to 9V, then switch the meter back on and check that the battery warning triggers when you drop the supply back to 7.0V.

And that’s it! If everything went as planned, you can fully assemble your new ESR meter and start finding defective electrolytic capacitors. But first, read the panel entitled “Driving The ESR Meter Mk.2” – it not only contains useful hints but list the precautions that must be followed as well.

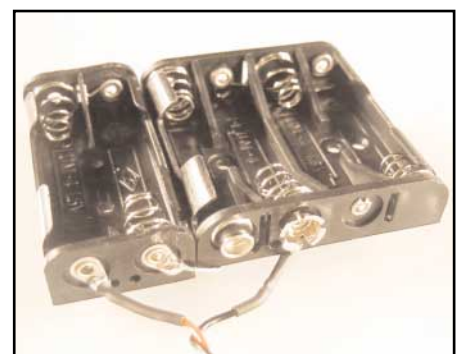

## Check These Fault Codes If It Doesn't Work

**W**hat if it doesn't work? In that case, the Mk.2 ESR Meter's firmware allows the microcontroller to do some basic testing of the electronics, to help you narrow down a problem to one area of the board.

Before doing the self-test, it's very important to first set VR1 to the centre of its adjustment range and make sure that the meter's supply voltage is in the range of 8.5-9.5V.

Now switch the meter on by pressing and continuing to hold the button down, regardless of what the displays are showing. After five seconds, they'll go blank for a moment, then show a test result for two seconds. The meter will then switch off by itself after you release the button.

If everything is more or less OK, you'll see ".8.8" on the displays (this shows that all the display segments and decimal point LEDs are working). However, if the microcontroller has detected a major problem, it will flash a fault code consisting of an "F" on the lefthand display and a character from 0-9 or an "A" on the righthand one.

Experience has shown that by far the most common cause of ESR meter kits not working properly is defective soldering. When a fault code directs you to a particular part of the circuit, carefully check (using a bright light and magnifier) for solder whiskers, non-soldered joints and track damage such as lifted solder pads.

If you can't see anything abnormal, start checking for incorrect components and component placement errors such as transistors of the wrong type or with their leads in the wrong holes. If that doesn't show up anything, you might have received a defective component in the kit, though this is very rare.

OK, here's a list of what the fault codes indicate:

F0: Q11 is not discharging C10.

Check around Q11 (BC338), R21 (10k $\Omega$ ), R22 (470k $\Omega$ ) and pin 4 of IC2 (Z86E0412).

F1: C10 is charging too quickly. Check that R22 really is 470k $\Omega$  and that R19 & R20 are 10k $\Omega$ . Make sure C10 is 470nF (0.47 $\mu$ F, code "474"). Check also for soldering and component placement problems around transistors Q9 & Q10 (BC558).

F2: C10 is charging too slowly (or not at all). Check around Q9, Q10 (BC558), R22 (470k $\Omega$ ), R19 & R20 (10k $\Omega$ ) and C10 (470nF).

F3: Pulse amplifier output bias <440mV (ie, at collector of Q8). Check R13 (100k $\Omega$ ) & R14 (220k $\Omega$ ) for correct values and check that D6 isn't reversed. Check around Q7 (BC548), Q8 (BC558) and around pin 8 of IC2 plus associated components.

F4: Pulse amplifier output bias >1V. Carry out the same checks as for "F3" code. Check also that D5 isn't reversed.

F5: A test current source is permanently on. Check area around Q3, Q4 & Q5 (all BC328); R5, R7 & R9 (2.2k $\Omega$ ); and pins 15, 16 & 17 of IC2.

F6: No output from pulse amplifier. This fault is usually due to the banana sockets being installed with +rt-circuiting them (see Fig.7). If that's not the problem, check around C7 (33nF), R12 (1k $\Omega$ ), D3 & D4 (1N4002), C5 (100nF) and C6 (47 $\mu$ F bipolar).

F7: Q3 not sourcing current. Check around Q3 (BC328), R5\* (2.2k $\Omega$ ), R6 (10k $\Omega$ ) and pin 15 of IC2.

F8: Q4 not sourcing current. Check around Q4 (BC328), R7\* (2.2k $\Omega$ ), R8 (1k $\Omega$ ) and pin 16 of IC2.

F9: Q5 not sourcing current. Check around Q5 (BC328), R9\* (2.2k $\Omega$ ), R10 (100 $\Omega$ ), IC2 pin 17.

FA: Q6 not switching on. Check around Q6 (BC338), R24 (10k $\Omega$ ) and pin 1 of IC2.

Obviously, the microcontroller

can't perform detailed tests on every component, so it's possible that your meter is malfunctioning even though the self-testing hasn't shown up a problem.

For example, if the meter is behaving strangely, "freezing" up or giving absurd readings on some values of test resistors, the most likely cause is a mix-up in the values of R6 (10k $\Omega$ ), R8 (1k $\Omega$ ) and R10 (100 $\Omega$ ).

On the other hand, if the meter produces readings but there's something wrong with the displayed characters, this is almost certainly due to one or more solder bridges between the pins of the large socket holding the displays, or around IC3.

If the meter doesn't stay switched on when you push the button, check around Q2 (BC338), R3 (15k $\Omega$ ), R29 (2.7k $\Omega$ ) and pin 2 of IC2. If it switches off when you short the test leads, R2 (4.7k $\Omega$ ) may be the incorrect value or Q1 (BC328) may have a low current gain.

Finally, if you can't get the meter into the test mode, zero it or switch it off, check for solder "whiskers" and open circuits around pin 3 of IC2, R4 (47k $\Omega$ ) and D2.

If none of the above has helped you to identify the problem, there's a page of fault-finding information on my website:

<http://members.ozemail.com.au/~bobpar/esrprob.htm>.

Do a Google search for "ESR meter faultfinding" if you can't find it. Also Ben Cook in Perth will get your meter working for a reasonable fee plus postage and handling. You can contact him at: [benok@iprimus.com.au](mailto:benok@iprimus.com.au).

\* The R5/7/9 area of the board seems to be a "magnet" for solder bridges and whiskers.

# Optional Modifications

## Heavy-duty protection

To provide greater protection against connection to charged electrolytics, some kit builders have connected an inverse-parallel pair of 1N5404 (or similar) high-power diodes between the test lead sockets. So if you're the kind who's likely to connect the meter to the 120 $\mu$ F input filter capacitor of a 240V-powered switching power supply without checking that it's been properly discharged, this modification is for you.

Reportedly, this protects the meter quite well, although it can result in the probe tips being blown off by large charged capacitors. The resulting surge current can also damage the charged capacitor and the power diodes themselves.

However, without the diodes, the resulting >600A current spike destroys the microcontroller (IC2) and damages C6.

## Improving battery life

If you'd like to get even more battery life out of the meter (and are feeling a bit adventurous), you can replace IC1 (78L05) with an LP2950CZ-5.0 and replace R26 (10k $\Omega$ ) with a 27k $\Omega$  resistor. That done, adjust trimpot VR1 so that the low battery warning triggers at 5.6V instead of the original 7.0V. (Thanks to G. Freeman, South Australia for this idea which was published in the August 1998 issue of "Electronics Australia" magazine).

## Disabling automatic switch-off

If you'd like to power the meter from an external 9V DC supply and have it operating continuously, just disconnect one end of R25 (47k $\Omega$ ). This disables the automatic switch-off function but note that the low battery warning will no longer work if you do this.

Of course, you can easily reconnect R25 if you change your mind in the future.

For more modifications, including a buzzer to help you discriminate between good and bad electrolytics without having to look at the meter, go to my ESR Meter Hints web page at

<http://members.ozemail.com.au/~bobpar/esrhints.htm>

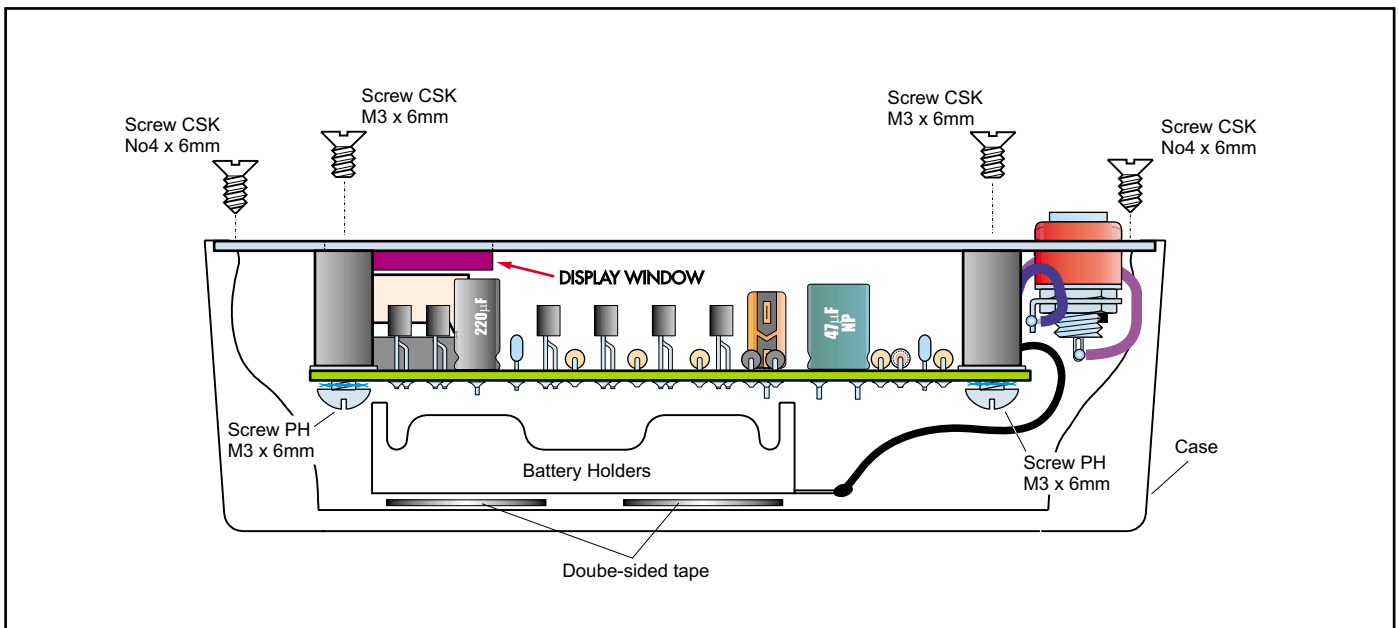
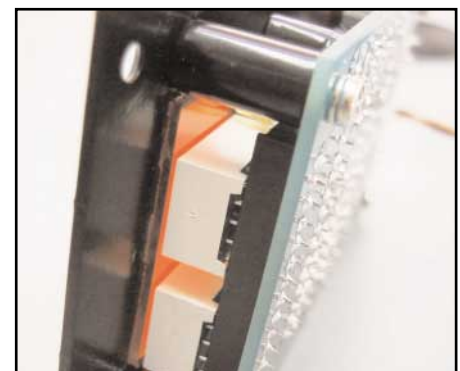
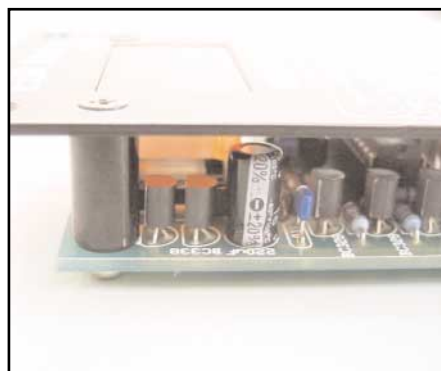
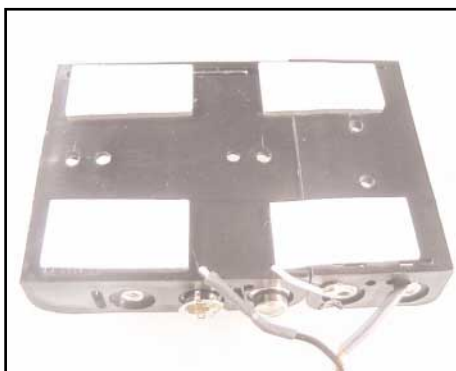

Fig.13: the battery holder is positioned on the bottom of the case and held in place by double sided tape.



## Driving The ESR Meter Mk.2

The ESR Meter is extremely simple to operate but there are a few precautions to follow. First, here's its basic step-by-step operation:

- (1). Insert the plugs of the test leads into their sockets.
- (2). Press the button so the "-" symbol appears on the display.
- (3). Hold the test probes tightly together – the test lead resistance is displayed.
- (4). With the probes still together, press the button again to give a zeroed reading of ".00". You can repeat this at any time.
- (5). Measure the capacitor's ESR (it should be discharged first). A reading of "-" indicates a reading greater than  $99\Omega$ .
- (6). When you've finished measuring, press the button with the probes separated. The meter switches off when you release the button.
- (7). When the battery is getting low, "b" flashes once per second and the display dims to conserve the remaining battery capacity.

### Precautions

**(1). Beware charged capacitors:** the very first thing to do is to make certain that the equipment you'll be using the ESR Meter on is disconnected from all power. Most electrolytic capacitors will be discharged by the circuitry around them within a few seconds of the power being switched off. However, be warned that filter capacitors in power supplies can remain dangerously charged, especially if there's a fault.

Before using the meter, make sure that all power supply capacitors are fully discharged. You can do this using well-insulated probes that include a series  $100\Omega$  5W or similar power resistor. Don't just short the capacitor's terminals together; it can not only damage the capacitor but can also be dangerous.

Always allow several seconds to ensure a complete discharge. Apart from the risk of surprise and injury to you, large charged capacitors can seriously damage

the meter. If you think your ESR meter might be accidentally connected to electrolytics that are charged to high voltages, consider the extra protection idea described in the "Optional Modifications" panel.

**(2). Watch out for interference:** the meter can produce unsteady indications if its test leads pick up strong horizontal deflection signal voltages. To avoid this, be sure to keep it away from operating (CRT) TVs and monitors when making measurements.

**(3). Use straight test leads:** don't use self-retracting "curly" test leads with your meter. Their inductance can cause measurement errors. Also, be very careful not to confuse the ESR Meter's test leads with those from your multimeter! Keep them well separated.

### What else can it do?

Since publication of the Mk.1 design in 1996, I've received a lot of feedback from imaginative ESR Meter users regarding other uses for it. The full list is on my website at

<http://members.ozemail.com.au/~bobpar/esrhints.htm> but here are some of the best ones:

**(1). Resistance Measurement:** as stated previously, this meter is really an AC ohmmeter with an equivalent test frequency of about 100kHz and capable of measuring non-inductive resistances from  $0.01\Omega$  to  $99\Omega$ . As such, it can be useful for locating short circuits on PC boards by showing the resistance of a copper track decreasing or increasing as you approach or move away from the short. For example, this is useful when trying to identify which one in a paralleled set of power

transistors is shorted (thanks Mike Diack).

You can also make your own very low-value resistors by measuring out a length of nichrome or similar resistance wire to give the required resistance. In addition, the ESR Meter can be used to check the contact resistance of switches, connectors and relays.

Just remember that any significant amount of inductance will cause measurement errors. You can't measure the DC resistance of a choke, transformer winding, video head or a roll of electrical cable, for example.

**(2). Basic Signal Generator:** the meter's test signal is a 500mV P-P (open circuit) burst of 8ms pulses at a 2kHz rate, repeated several times per second. As a result, it can be used as a signal source for basic checks on amplifiers, loudspeakers and other audio components (thanks Joe Lussy).

### Maintenance

The meter's readings might become unsteady after a lot of use, due to oxidation or loosening of the test lead sockets. Heavily spray the test lead plugs with contact cleaner of the kind which evaporates completely (eg, CRC "CO" Contact Cleaner), then repeatedly insert and withdraw them from their sockets before it dries. If the test lead sockets have become loose, gently re-tighten them with long needle-nose pliers.

If the test probes have developed a resistive layer of oxidation, give them a wipe with a tissue soaked in tuner cleaner like CRC 2.26 or similar (thanks Joe Sopko).



## Identifying Defective Electrolytics

If you're getting the idea that it's tricky to identify defective electrolytics, relax! Experience has shown that in almost every case, a capacitor's ESR needs to rise to at least 10 times its normal value to cause a circuit malfunction. Often, you'll find that it's risen to >30 times its normal value, or is so high that the meter just displays "-" (ie, >99Ω). So, with few exceptions, the electrolytic capacitor(s) causing a fault will be very obvious.

It's for this reason that the front panel figures don't need to be extremely accurate or complete. When you encounter an electrolytic whose value or voltage isn't on the chart, it's sufficient to assume that its ESR should be similar to that of a capacitor adjacent to it on the chart.

If you have any doubts, it's best to compare the meter's reading on a suspect capacitor with that of a new capacitor of the same value and voltage rating.

Note that the electrolytics which fail are often the ones that are close to heat-generating components such as power semiconductors and resistors, so check these first. It will save time if you mark each good capacitor with a felt-tipped pen as you go, so you know which ones still need to be checked.

### Traps to avoid

All test equipment can produce

misleading indications under some conditions and the ESR Meter is no different. Because it is basically a high-frequency AC ohmmeter, it can't discriminate between a capacitor with a very low ESR and one which is short-circuit or very leaky.

In general, electrolytics with high ESR will cause faults such as switching power supplies losing regulation or failing to start, high-frequency noise in signal circuits, and distorted scanning waveforms in monitors and TV sets. In vintage equipment, they can cause hum and low frequency instability ("motorboating"), etc.

Conversely, leaky or shorted capacitors are likely to disturb the DC conditions of the circuit they are in, producing quite different kinds of faults. Tests with a multimeter should locate these. That said, in several decades of working on electronic gear, I've encountered less than a dozen shorted electrolytics but hundreds with high ESR!

If you find an electrolytic giving an ESR reading which seems too good (low) to be true, disconnect it from the circuit and measure its resistance with an ohmmeter – it might be short-circuit. In fact John Robertson from "John's Jukes" in Canada found that a cheap digital multimeter on a low ohms range can be connected in parallel with the ESR Meter without them dis-

turbing each other. Doing this allows the multimeter to show up those rare shorted electrolytics while you simultaneously check the ESR.

In some circuits such as in computer motherboards, switching power supplies and TV/monitor deflection stages, electrolytic capacitors are connected directly in parallel. In that case, a good capacitor can make the ESR of a (parallel) bad one appear to be much lower than it really is. You need to be aware of the circuit your suspect capacitor is in and disconnect it from circuit before making a measurement if necessary.

### Beware Of Good ESR With Reduced Capacitance!

There's one more failure mode that you need to be aware of: when the ESR remains perfectly OK but the capacitance has dropped by a large amount. This is apparently quite rare but when it does happen, it can cause a lot of confusion.

If your ESR Meter shows that all the electrolytics seem OK but some strange fault is still present. try disconnecting and checking each capacitor in turn with capacitance meter. Alternatively, you could try temporarily connecting new capacitors in parallel with any suspect units (after turning the power off and discharging them).

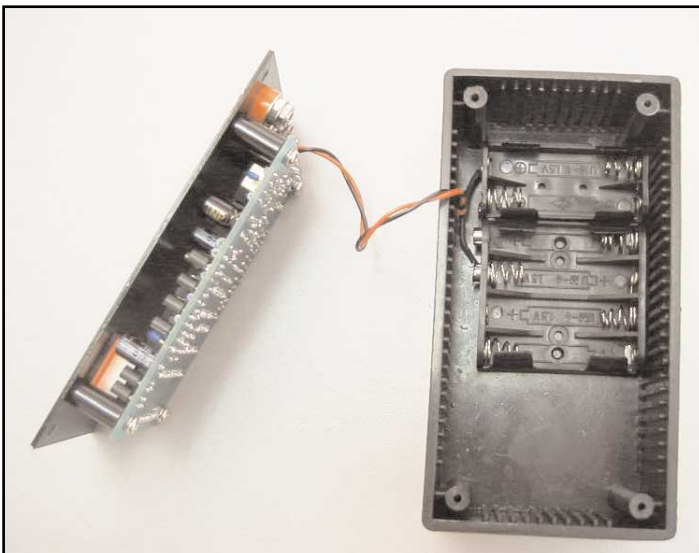

**DICK SMITH**  
ELECTRONICS

A.B.N. 34 000 908 716

Main Electronic Supplies Ltd 4554 Main Street Vancouver BC V5V 3R5

WEBSITE: [www.mainelectronics.com](http://www.mainelectronics.com)

PH: 604-872-0267 Fax: 604-872-0268